

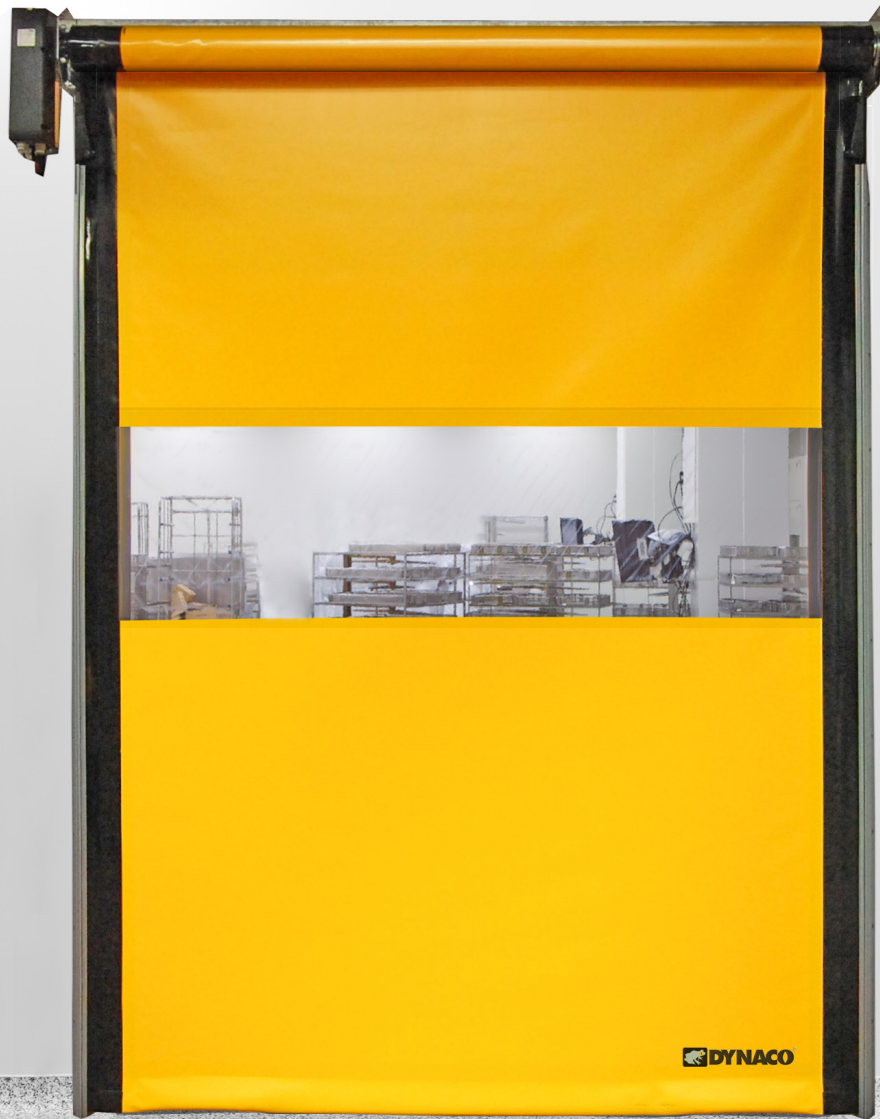

ENTRE//MATIC



DYNACO D-310

**Gravity
driven**

low friction technology



inside door

www.dynacodoor.com

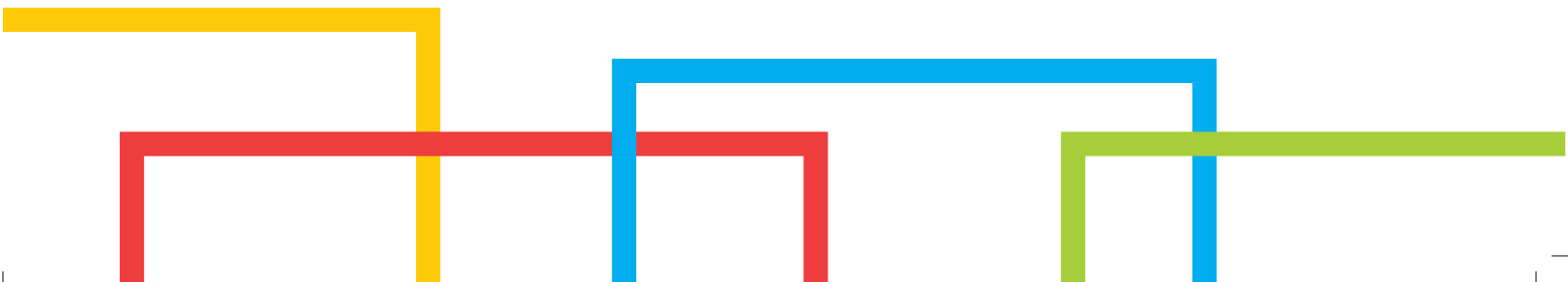

DYNACO D-310

The Dynaco D-310 LF (Low Friction) is designed for inside applications. It is a perfect, entry level solution for applications targeting 25.000 cycles per year.

As all Dynaco doors, the D-310 LF requires little space. It protects your installation against drafts, humidity, dust and dirt. With its speed and good seal, the D-310 LF improves your traffic flow and increases employee comfort.

A Dynaco D-310 LF door also assures significant savings on energy costs.

- **OPENING SPEED:**
Up to 1 m/s.
- **GOOD SEAL:**
The patented side guides and «BEAD» technology provide a good seal and allow energy savings.
- **CRASH FORGIVING AND SELF-REINSERTING WITHOUT INTERVENTION:**
The curtain reintroduces itself automatically after a crash. This reduces maintenance cost and production down time.
- **USER SAFETY:**
The flexible curtain moulds itself. It contains no rigid elements. Therefore, it increases user safety.
- **ADVANCED DRIVE:**
Wearable elements are reduced to a minimum.
- **CONFORM TO EN13241-1**

Printable curtain

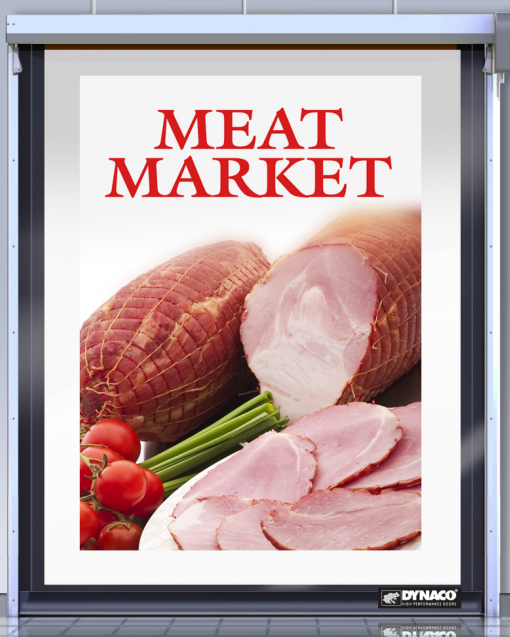

Motor with optional covers



Gravity driven

low friction technology



inside door

EN13241-1 STANDARDS

Standard	Ref.	Test acc.	Results
Water permeability	EN 12425	EN 12489	0
Wind load	EN 12424	EN 12444	Class 1*
Wind permeability	EN 12426	EN 12427	0
Safe openings	EN 12453	EN 12445	Pass
Mechanical resistance	EN 12604	EN 12605	Pass
Unintended movements	EN 12604	EN 12605	Pass

* Interior applications only

CHARACTERISTICS

Max. dimensions	W 3.000 mm x H 3.000 mm																
Opening speed Closing speed	up to 1 m/s up to 1 m/s																
Structure	Folded steel 37 x 52 x 3 mm, galvanised before cutting and folding																
Drum	Steel - Ø 102 x 2 mm.																
Side guides	Reinforced polyethylene (PE-UHMW1000)																
Motor	2 poles, with brake. Power 0,5 kW Protection degree: IP 54 Integrated controller																
Commands	Push buttons open-close-stop standard																
Standard detectors	Infrared barrier: 60 mm from the floor. DBD: correct unwinding detector																
Power supply	Three phased 230 V / 400 V - 6 A / 3 A Single phase not available																
Frequency	Frequency: 50 Hz																
Advised operating temperature	+ 5 °C up to + 40 °C																
Available colours comparable with:	<table border="0"> <tr> <td>Yellow RAL1003</td> <td></td> <td>Green RAL6005</td> <td></td> </tr> <tr> <td>Orange RAL2004</td> <td></td> <td>Grey RAL7035</td> <td></td> </tr> <tr> <td>Red RAL3000</td> <td></td> <td>White RAL9010</td> <td></td> </tr> <tr> <td>Blue RAL5002</td> <td></td> <td>Black RAL9005</td> <td></td> </tr> </table>	Yellow RAL1003		Green RAL6005		Orange RAL2004		Grey RAL7035		Red RAL3000		White RAL9010		Blue RAL5002		Black RAL9005	
Yellow RAL1003		Green RAL6005															
Orange RAL2004		Grey RAL7035															
Red RAL3000		White RAL9010															
Blue RAL5002		Black RAL9005															
[Actual colours may deviate. Colour samples available upon request]																	

Low friction side guide

Optional covers



Reintroduction block^{PT}



Dimensions and installation requirements Dynaco D-310

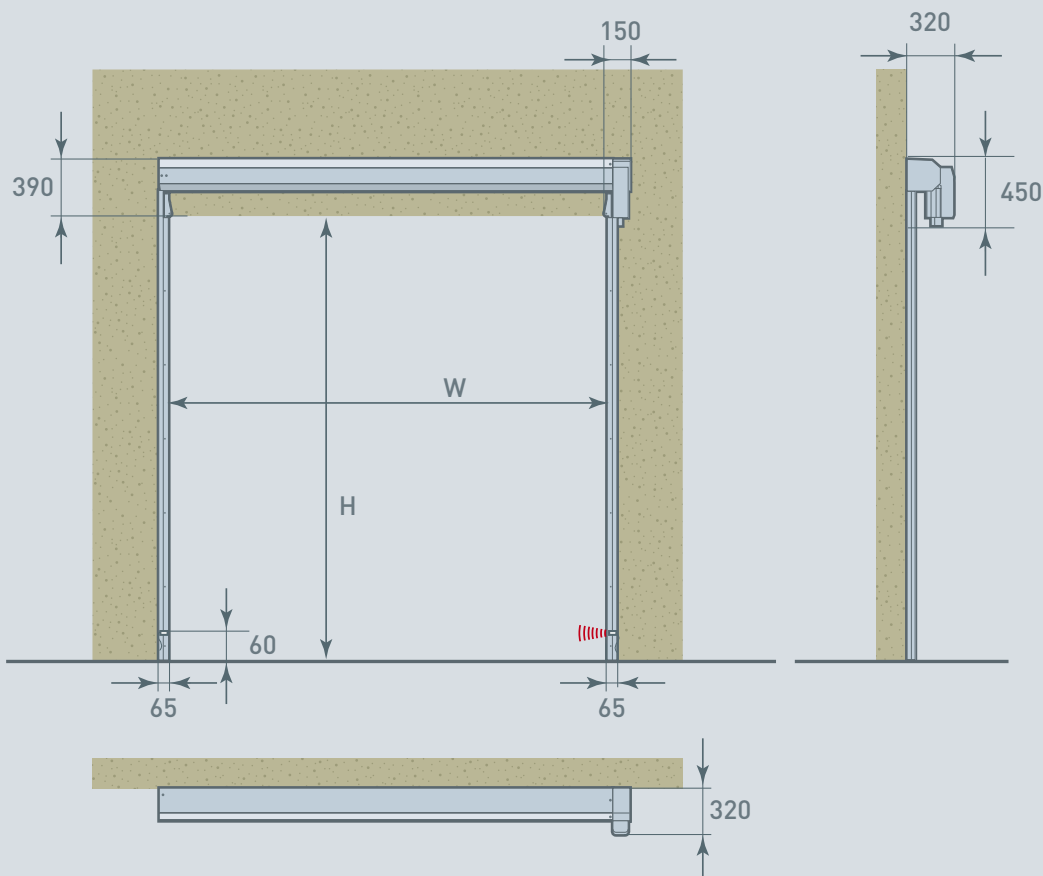

All indicated dimensions are based on exact width and height dimensions only. The space necessary for mounting and maintenance has to be provided.

REMARK: Based on the risk analysis of the environment, extra push buttons, detectors and covers might be required.

© Entrematic Group AB – 2016

Entrematic offers a comprehensive range of products for industrial, commercial, institutional and residential applications, including sectional doors, loading dock equipment, high-performance doors, residential garage doors, pedestrian doors, gates and barriers, and automation and operators. Built on nearly 200 years of accumulated expertise, Entrematic aims to be the most dynamic, innovative company in the entrance automation industry, and the best partner for dealers and installers. Our well-known brands include Normstahl, Dynaco, Ditec and EM.

Entrematic, Amarr, Kelly, Serco, Normstahl, Dynaco, Ditec and EM, as words and logotypes, are examples of trademarks owned by Entrematic Group AB or companies within the Entrematic Group.

The Dynaco products are protected by worldwide registered patents. As part of its policy of continuous product development, Entrematic Belgium NV reserves the right to change the characteristics of its products or components without prior notice.

Disclaimers:

For a correct use of our products, please refer to our manual.

Everything that is mentioned in this brochure is only valid under the terms of use in the user manual and on condition that the door was properly installed and maintained and has not undergone abuse nor neglect.

ENTREMATIc BELGIUM NV
 Waverstraat 21
 B-9310 Moorsel-Aalst (Belgium)
 Tel. +32 53 72 98 98
 Fax. +32 53 72 98 50
 info.dynaco.eu@entrematic.com
 www.dynacodoor.com

ENTREMATIc

