



## Design Highlights

- **airDefense™** Proprietary Stump Out & Freefall Protection System with 60,000 lbs. Structural Dock Level Support Legs
- Clean Pit Kit
- High Volume, Low Pressure Air Bag Lifting Mechanism Requires No Scheduled Maintenance
- NEMA 4x Non-Metalic Push-button (Non-Interlock Capable Control Box)
- Lifting Bag Operates Under Temperature Extremes of -65° to +180°F
- Lifting Bag with Polyvinylchloride Coated Polyester Fibers Retains Lifting Effectiveness Even When Punctured (Easily Repaired with Vinyl Patches)
- Lifting Bag, Gaskets & Fittings Resistant to Chemical Wash-down Exposure & Rodent Damage
- 16" Long Lip
- Exclusive Lambda Deck Beams
- Full Operating Range Toe Guards
- GRAVITY LIP™ Automatic Lip Extension with Every Cycle
- Self-cleaning Lug-type Lip Hinge with Rated Lifetime Warranty
- Integral Support Strut & Lip Lock

## Project Information

Job Name \_\_\_\_\_  
 Address \_\_\_\_\_  
 General Contractor \_\_\_\_\_  
 Distributor \_\_\_\_\_  
 Model \_\_\_\_\_ Quantity \_\_\_\_\_

## Certified For Construction

By \_\_\_\_\_  
 Company \_\_\_\_\_  
 Address \_\_\_\_\_  
 Date \_\_\_\_\_

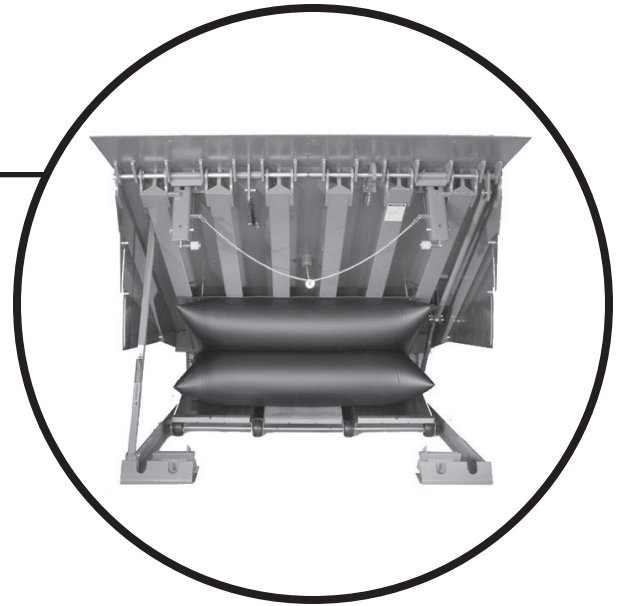

## Available Options

- NEMA 4 Control Box (Interlock Capable)
- Dynaseal Weatherseal
- Spacer Kit for Existing & Sloped Pits
- 18" Lip
- 20" Lip
- 24" Pit Conversion
- Longer Lip Chamfer
- Spray Foam Insulated Deck
- Spray Metallized Ramp, Lip & Frame
- High Lip Bend
- Curb Angle Sets
- Pan Option:  
 For installation without pre-formed concrete pits, dockleveler supplied with integral pre-formed steel pan for pour-in-place construction.  
 Dockleveler shall be in an enclosed steel pan structure complete with its own six-piece welded structural curb angles and concrete anchors. The dockleveler is to be concreted in place as the floor is poured.
- Other \_\_\_\_\_



**Pan Option**

## Accessories

- STAR® Trailer Restraint \_\_\_\_\_
- AUTO CHOCK® Wheel Restraint
- SURFACE CHOCK™ Wheel Restraint
- Hidden Hook™ Recessed Restraint
- TRUK ALERT® Illuminated Loading Dock Communications Package
- Integrated Control Panel

## Bumper Options

- 410-14
- 610-14
- 610-14R
- VB420-11F
- VB420-11 Steel Faced
- Other \_\_\_\_\_

## Capacity

- 25K  30K  35K  40K  45K  50K

**aFX SERIES DOCKLEVELER**  
 AIR-POWERED SPECIFICATIONS



**FIRST. AND BUILT TO LAST.**

1612 Hutton Drive, Suite 140 ▾ Carrollton, TX 75006, USA ▾ Tel: 800-558-6960 ▾ Fax: 972-389-4766 ▾ Email: kelley@dockproducts.spx.com ▾ www.kelleycompany.com  
 A continuing research program is in effect at Kelley. We reserve the right to incorporate product improvement at any time without prior notice.



aFX SERIES DOCKLEVELER  
AIR-POWERED SPECIFICATIONS

**1. General:** Kelley's "aFX" airForce Technology dockleveler with **airDefense™** system to be complete package, including motor housing assembly, full operating range toe guards, integral support struts for deck and lip lock. Units available in 25,000 - 50,000 lbs. capacities. Unit conforms to ANSI MH14.1-1987 performance requirements. Unit to be manufactured by Kelley.

**2. Construction, Platform Assembly:** Platform to be constructed of unitized, robotically welded 50,000 PSI yield safety tread deck plate. Exclusive Lambda deck beams optimize twist resistance and stress distribution.

**3. Lip Assembly:** Self-cleaning lug-style lip hinge comes standard with heavy lugs welded directly to each beam and lip assembly. Comes standard with a rated lifetime lip hinge warranty. All units to be 16" 50,000 PSI yield safety tread deck plate with chamfered leading edge.

**4. Lip Extension:** GRAVITY LIP™ Automatic Lip Extension ensures proper lip extension with descent of dockleveler into trailer.

**5. Rear Subframe & Hinge:** Fixed rear hinge provides 4" of side-to-side tilt without gap at rear hinge.

**6. Power Unit:** Power unit is an electric motor and blower.

**7. Electrical:** Fan motor is 115V single phase. Air bag and fan motor assembly are mounted to galvanized pan subassembly.

**8. Pit Cleaning System:** All Kelley docklevelers are built with an open frame design to provide easy access to the pit floor for routine cleaning and scheduled maintenance. The aFX, built with patented standard **Clean Pit Kit**, eliminates need for any additional tools for complete access to the concrete floor or access to the fan motor for routine cleaning.

**9. Control Panel:** NEMA 4x (Non-Interlock Capable), nonmetallic, single push-button control panel.

**10. Product Finish:** Baked enamel green paint finish.

**11. Safety Legs:** **airDefense** sensor rollers ride along reinforced cams, providing fluid free float motion to eliminate stump-out while also providing a measure of freefall protection in the event of premature trailer separation. High-efficiency 60,000 lbs. structural dock level support legs. Drop-tested to the full rated capacity of the dockleveler.

**12. Below-dock Control (End-loading):** Kelley's **airDefense** system allows for lowering of leveler without extending lip.

**13. Toe Guard Protection:** Full operating range toe guards with two galvanized sliding guards (yellow OSHA required markings per ANSI/Z535.1) provided on the sides of the dockleveler.

**14. Integral Support Strut:** Integral support strut keeps ramp raised during routine maintenance and pit cleaning.

**15. Integral Lip Lock:** Lip lock keeps lip raised for routine maintenance and cleaning.

**16. Float Compensation:** Allows for vertical carrier deflection when lip is in contact with truck bed.

**17. Operation:** Kelley's "aFX" Dockleveler rises when NEMA 4x shielded push-button is pushed and held. GRAVITY LIP™ automatically extends as deck section descends into trailer bed. After loading or unloading is complete dock attendant pushes button to activate air system and raise dockleveler. GRAVITY LIP™ moves pendant and dockleveler is stored. In stored position, dockleveler is fully supported by dock level support legs. Ramp may be lowered to fully supported below dock level position without extending lip, to service low trucks in end load situations.

**18. Installation:** Unit shipped completely assembled and ready for installation in pre-formed concrete pit. Pit depth is 20" for 6' and 8' long units and 24" for 10' long units. Pit construction to be in accordance with certified Kelley pit detail drawings. Contact Kelley for current cost and nearest distributor.

**19. Limited Warranty:** Limited lifetime (rated) lip hinge warranty. Limited 5-year parts & labor warranty on lifting system (bag, motor, hoses, gaskets, fittings, & seals). Limited 1-year parts and labor warranty on remaining components. Limited 10-year structural warranty available upon engineering approval of written application.

**20. Bumpers:** Unit to include two heavy-duty dock bumpers model 410-14R (4"Thick x 14"W x 10"H).

NOMINAL DIMENSIONS

MODEL	WIDTH	LENGTH
aFX6X6	6'	6'
aFX6.5X6	6'6"	6'
aFX7X6	7'	6'
aFX6X8	6'	8'
aFX6.5X8	6'6"	8'
aFX7X8	7'	8'
aFX6X10	6'	10'
aFX6.5X10	6'6"	10'
aFX7X10	7'	10'

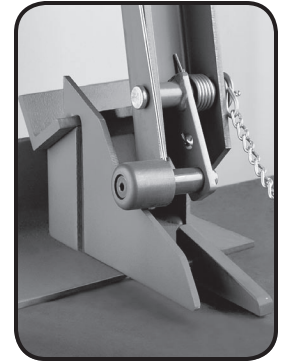

airDefense™  
Sensor Roller

*Kelley products may be covered by one or more of the following U.S. patents or patents pending.*

4,776,052 4,847,935 4,928,340 4,937,906 4,961,241 4,974,276 4,977,635 4,979,253 5,001,799 5,042,103 5,088,143 5,097,557 5,117,526 5,157,801 5,303,443 5,313,681 5,396,676 5,459,963 5,446,938 5,460,460 5,471,693 5, 75,888 5,481,774 5,500,968 5,511,267 5,522,107 5,522,108 5,526,545 5,544,381 5,553,343 5,586,355 5,586,356 5,600,859 5,651,155 5,774,920 5,802,650 5 802,651 5,813,072 5,826,291 5,831,540 5,832,554 5,881,414 5,926,890 5,996,156 6,006,389 6,035,475 6,125,491 6,327,733 6,360,393 6,370,719 6,405,397 6,460,212 6,487,741 6,594,842 6,711,774

KELLEY

FIRST. AND BUILT TO LAST.

1612 Hutton Drive, Suite 140 ▾ Carrollton, TX 75006, USA ▾ Tel: 800-558-6960 ▾ Fax: 972-389-4766 ▾ Email: kelley@dockproducts.spx.com ▾ www.kelleycompany.com  
A continuing research program is in effect at Kelley. We reserve the right to incorporate product improvement at any time without prior notice.